

LiftMotive

Scissor lift tables take the strain when you need to lift and manoeuvre heavy items through small distances. The use of lift tables ensures an efficient optimising of the employees working conditions, working at a proper height, avoiding repetitive heavy lifting and therefore also many health issues. Lift tables can be used in furniture manufacturing, transportation, woodworking industries as well as in metalworking, automotive areas and warehousing.



LiftMotive

Full-rise scissor lifts specifications

	A (mm)	B (mm)	C (mm)	D (mm)	Capacity (kg)
LM-350FRST	905	500	1500	360	350
LM-500FRST	905	500	1500	360	500
LM-800FRST	1200	610	1500	450	800
LM-1000FRST	1200	610	1700	500	1000

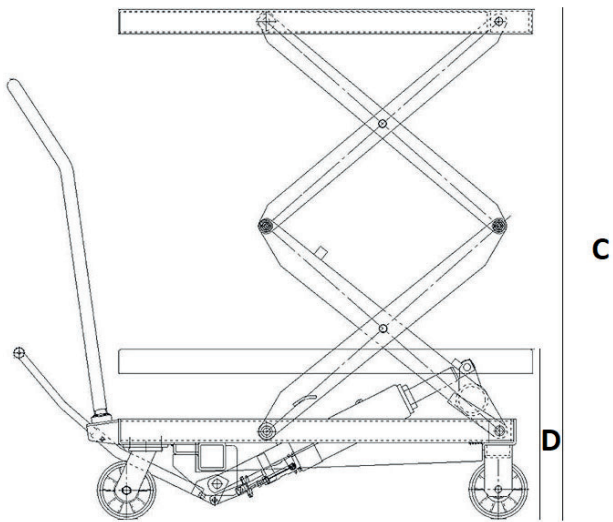
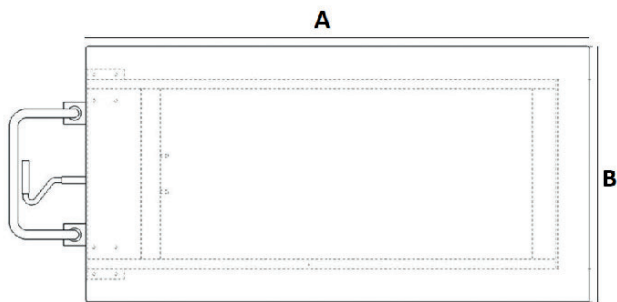

LiftMotive

Mid-rise scissor lifts specifications

	A (mm)	B (mm)	C (mm)	D (mm)	Capacity (kg)
LM-150MRST	700	450	720	210	150
LM-500MRST	815	500	900	280	500
LM-1000MRST	1016	510	1000	410	1000

